

# Private Pad : MuteBox

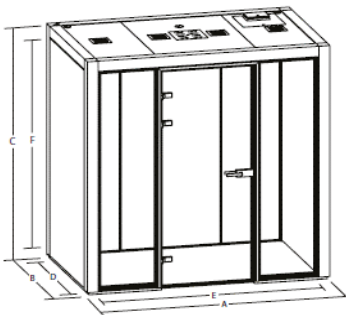

Reference product

\*The Element poufs shown above are part of the "Lounge" Environmental Sheet.



**Manufacturer** Artopex Inc.  
**Category\*** Mute Box  
**Description** Collab Mute Box - 2 to 4 occupants.  
 Offered with hinges and handles on the left or right. The exterior walls and roof are available in laminate and the interior is available in felt. The floor is available in carpet (2 choices of color). Includes: ventilation system, lights and power supply with circuit breaker.

**Final assembly location** Division Pro Systemes Inc. 1050 Boul. Industriel, Granby QC J2J 1A4, Canada

**Reference product** Mute Box

\*Category as defined by ANSI/BIFMA e3 (certification Level).

**Contact - Customer Service**

sac@artopex.com  
 1 833 363-3041  
 Pro-Meubles, 800 Vadnais Street  
 Granby QC J2J 1A7 Canada

**Contact - Environmental Service**

eco@artopex.com  
 1 800 378-0189  
 Pro-Meubles, 800 Vadnais Street  
 Granby QC J2J 1A7 Canada

Recycled Content*	Material weight		Pre-consumer %	Post-consumer %	Total recycled %	Re-use Recycling Valorization***
	Lbs.	%				
Material	Lbs.	%	%	%	%	
<b>Glass</b>	857,7	54,3	0,0	0,0	0,0	YES
<b>Laminate</b>	396,0	25,1	69,7	17,6	87,2	YES
<b>Aluminum</b>	230,0	14,6	0,0	0,0	0,0	YES
<b>Felt</b>	34,1	2,2	0,0	50,0	50,0	YES
<b>insulation wool</b>	16,0	1,0	0,0	100,0	100,0	YES
<b>Metal alloy (Steel type 2)</b>	15,0	0,9	19,5	69,0	88,5	YES
<b>Nylon</b>	12,0	0,8	34,0	35,0	69,0	YES
<b>Electrical components</b>	18,0	1,1	19,5	69,0	88,5	YES
<b>PVC (Gasket)</b>	1,5	0,1	19,5	69,0	88,5	YES
<b>Total</b>	1580,3	100,0	18,1	8,2	26,3	

\*Calculation based on a minimum of 95% of product weight.

\*\*Steel type 1: Data from supplier / Type 2: Average steel industry rate.

\*\*\*Reuse possibilities, recycling and recovery vary according to the geographical location of the product at the end of its life.

**Certifications**



**Extra Documentation**

[Corporate Social Responsibility Report](#)

[Certifications \(details\)](#)

[Cleaning Guide](#)